

Sept. 15, 1942.

G. G. CAMARENA

2,296,019

CHROMOSCOPIC ADAPTER FOR TELEVISION EQUIPMENT

Filed Aug. 14, 1941

3 Sheets-Sheet 1

Fig. 1.

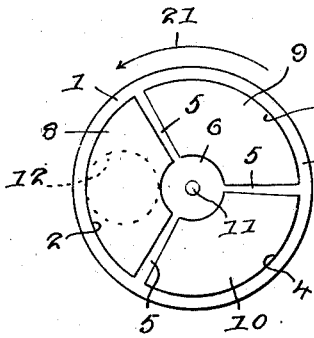

Fig. 2.

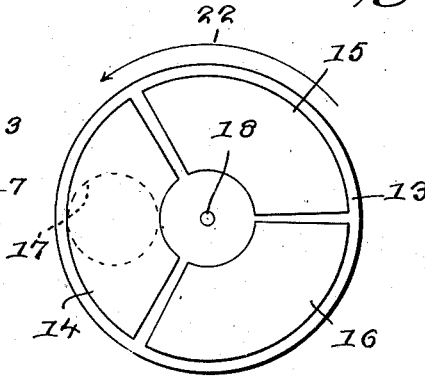

Fig. 3.

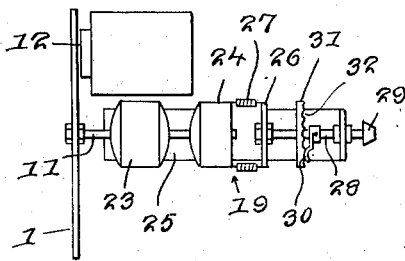
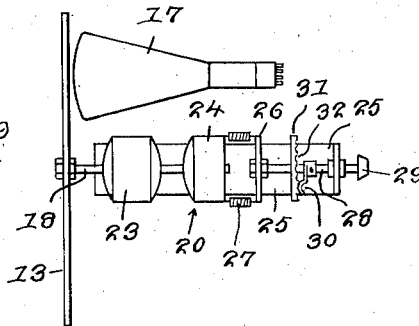

Fig. 4.



INVENTOR.
Guillermo G. Camarena
BY
Victor J. Evans & Co.
ATTORNEYS

Sept. 15, 1942.

G. G. CAMARENA

2,296,019

CHROMOSCOPIC ADAPTER FOR TELEVISION EQUIPMENT

Filed Aug. 14, 1941

3 Sheets-Sheet 2

Fig. 5.

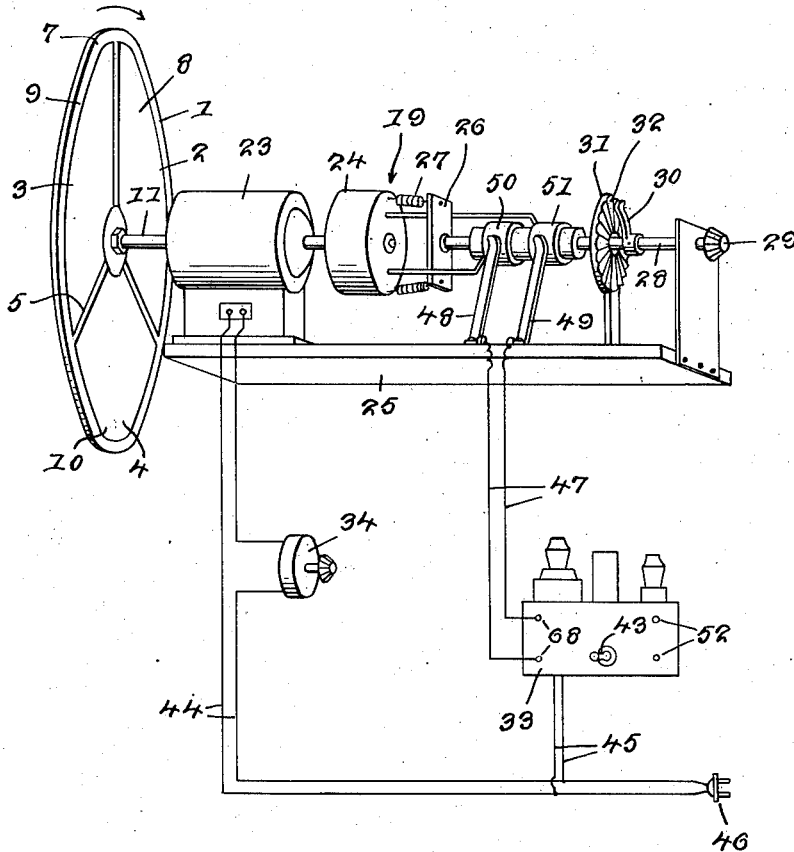

INVENTOR.
Guillermo G. Camarena
BY
Victor J. Evans & Co.
ATTORNEYS

Sept. 15, 1942.

G. G. CAMARENA

2,296,019

CHROMOSCOPIC ADAPTER FOR TELEVISION EQUIPMENT

Filed Aug. 14, 1941

3 Sheets-Sheet 3

Fig. 6.

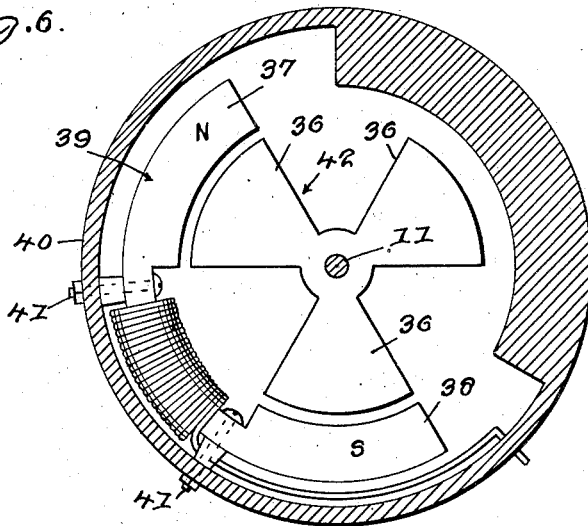
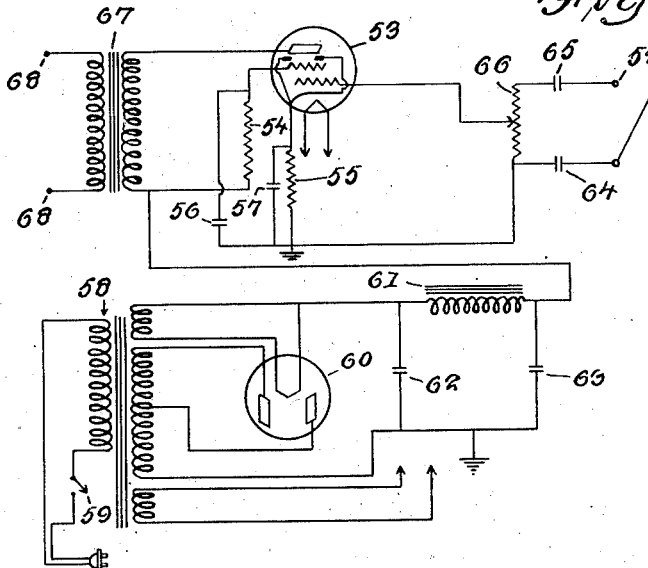

Fig. 7.



INVENTOR.
Guillermo G. Camarena
BY
Victor J. Evans & Co.
ATTORNEYS

UNITED STATES PATENT OFFICE

2,296,019

CHROMOSCOPIC ADAPTER FOR TELEVISION EQUIPMENT

Guillermo González Camarena, Mexico City,
Mexico

Application August 14, 1941, Serial No. 406,876
In Mexico August 19, 1940

1 Claim. (Cl. 178—5.4)

My invention relates to the transmission and reception of colored pictures or images by wire or wireless, and has among its objects and advantages the provision of an improved chromoscopic adapter for television equipment and operated with cathode rays. Television apparatus for colored picture work is of an exceedingly complicated nature and is not adaptable to standard television equipment now in use. The present invention may be easily adapted to any transmitter or receiver of "black and white" television equipment.

In the accompanying drawings:

Figures 1 and 2 illustrate light filter units for association with a television camera and a television receiver, respectively;

Figures 3 and 4 are diagrammatic plan views illustrating the manner of installation of the light filters with respect to the television camera and the television receiver, respectively;

Figure 5 is a perspective view of a complete adapter illustrating its component parts and wiring;

Figure 6 is a sectional view illustrating the inside structure of a synchronous motor; and

Figure 7 is a diagrammatic view of the electric circuit of the amplifier.

In the embodiment selected for illustration, Figure 1 illustrates a disk 1 of wood or any other suitable material, which disk is provided with three openings 2, 3 and 4 whose total area is slightly less than the area of the disk 1, the respective openings being separated one from the other through the medium of arms 5 which connect the central disk area 6 with the ring 7 constituting the outer circumferential margin of the disk. Extending across the respective openings 2, 3 and 4 are three light filters 8, 9 and 10 colored red, green and blue, respectively.

The light filters may be cemented or otherwise secured to the disk 1 and are of pure colors and may comprise glass or other suitable transparent material. The disk 1 is fixedly secured to a shaft 11. The dotted circle 12 denotes a television camera lens located behind the red light filter 8 and illustrates the relative sizes of the light filters with respect to the lens on the television camera.

The disk 13 of Figure 2 is similar to disk 1 with the exception that it is somewhat larger in diameter. Disk 13 is also provided with light filters 14, 15 and 16, respectively colored red, green and blue. The receiver screen is illustrated at 17 and the larger size of the disk 13, as compared with the disk 1, is necessitated

by reason of the size of the screen 17 which must be covered completely by the filters 14, 15 and 16.

Figure 3 illustrates the disk 1 connected with the shaft 11, while Figure 4 illustrates the disk 13 connected with a similar shaft 18. The respective units 19 and 20 of Figures 3 and 4 are identical with that illustrated in Figure 5, this figure illustrating the disk 1 in conjunction with the shaft 11. Since both units 19 and 20 are identical in construction and operation, the description of one will apply to both.

The operation of the structure so far described may be considered in relation to a television system of the cathode ray type operating normally at thirty picture squares per second. The disk 1 rotates in the direction of the arrow 21 so that the red, green and blue light filters 8, 9 and 10 successively sweep downwardly before the lens 12. If the number of turns of the disk 1 is three times less than the number of picture squares per second of the television system (in this case ten turns per second) the disk will displace thirty color squares per second, so that each color change will correspond to a picture change. Disk 13 rotates in the same direction, as indicated by the arrow 22. With the synchronism of both disks 1 and 13 established, the following phenomenon will be observed:

When the red filter 8 passes before the camera, only the red or white light of the object to be transmitted is perceptible for the lens 12. At the same time, the red filter 14 is passing before the screen 17 so that the image to be seen will be red.

When the scanning of the next picture begins, the green filters 9 and 15 will respectively pass before the lens 12 and the screen 17. As the camera scans the new image through the green filter, it is sensitive to white and green light only, the ones forming the image red and blue will not come through the filter to the lens. At the same time, the image will be seen on the screen 17 through the green filter 15. Meanwhile the red image will persist in the eye because of the inertia in the retina, which endures for about an eighth of a second. In the next picture, the blue filters 10 and 16 replace the green filters and now a process similar to the two mentioned above will take place, only that the image now explored by the camera corresponds to the white and blue places of the transmitted image; on the screen the image will be blue, which color completes the trichrome.

In the next turn of the disk, the process will be repeated as previously described so that in each eighth of a second (one turn) a synchronic trichrome will be displayed before the lens and the screen. The developing time of this process is faster than the pupillological inertia of the retina, so that a fired image in actual colors will apparently be seen on the screen. The three filters will give the same color combinations as are obtained in ordinary trichrome. The most convenient television cameras to be used are undoubtedly the Zworykin iconoscopic camera and the Farnsworth electronic camera, for the photocell mosaic of the first and the photosensitive cathode of the second have a color sensitivity very much the same as the human eye. In case that one of the cameras should not be sensitive enough to one of the colors, it is desirable to change the corresponding filter for a better one of the same color, so that this filter permits the camera to obtain more light, and equal excitation in every one of the three colors.

Fluorescent screens of modern receivers may be used since the light produced therein is completely white and the inertia of the fluorescent material is disposed by the thirty (or more) picture squares per second.

Synchronism and phasing of the disks

Under the term "synchronism of the disks," it is understood that both disks turn simultaneously and with the same number of revolutions three times less than the number of picture squares originated in the television system. Synchronism of the disks consists in moving the disk 1 in synchronism with the disk 13 so that the two sets of red, green and blue filters, respectively, simultaneously sweep across the lens 12 and the screen 17. Figure 5 illustrates the manner in which synchronism and phasing are accomplished.

The motor 23 is the principal moving organ of the adapter. An induction motor or any other type of brush motor may be used, since the function of this motor is to turn the adapter with a few more revolutions than are required for synchronism. The shaft 7, which comprises the motor shaft, is extended beyond both ends of the motor shell so as to constitute a mounting for the disk 1 at one end and a connection for a small impulse synchronic motor 24 at its other end. The motor 23 is fixedly secured to the base 25 but the motor 24 is free from the base and is held to a metallic plate 26 by springs 27. To the metallic plate 26 is connected a control shaft 28. The shaft 28 may be manually turned through the medium of a knob 29 and the shaft is yieldingly supported against accidental rotation by reason of a resilient finger 30 keyed to the shaft 28 and engaging a disk 31 having a grooved face 32 engageable by the finger 30, the disk being fixedly secured to the base 25.

The synchronic motor 24 is designed to operate with the same electric pulsations of relaxation that originate the picture change in the television system. These pulsations are amplified by an amplifier 33 so as to give an output of six to eight watts motor power. This motor controls the speed of the motor 23, operating within its power range as a brake or an accelerator.

A rheostat 34 is connected in series with the driving motor 23 and operates to adjust its speed to that of the synchronic motor 24. For the

same purpose, the shell of the motor 24 is spring mounted so as to give the motor the necessary flexibility in speed control so that a change in the speed of the motor 23 will not tug the movement of both.

Figure 6 illustrates the specific structure of the synchronic motor 24. To the shaft 11 is fixedly secured a cast iron rotor consisting of three equally spaced radial wings 36 to rotate relatively to the poles 37 and 38 of an electromagnet 39 fixedly secured to the non-magnetic shell 40 of the motor 24 through the medium of bolts 41. When the amplified synchronic pulsations of the television set are applied to the electromagnet, the latter will be magnetized at each pulsation and attract the two nearest wings 36. Consequently the rotor 42 revolves at small impulses following the frequency of the synchronizing current and making a complete revolution for each three pulsations. Since each pulsation corresponds to a picture change in the television set, the number of revolutions of the motor would be three times less than the number of picture changes, thus automatically achieving the required synchronism.

According to the previous description, the operation procedure for a color adapter installed in a camera or in a television receiver is as follows:

With the amplifier 33 turned off, the driving motor 23 is set into operation until it reaches a maximum speed. The switch 43 of the amplifier is then actuated so that the synchronic motor 24 begins to move and slow down the driving motor 23 until the latter revolves at the synchronous speed. Thereupon the rheostat 34 is adjusted until the greatest stability in the functioning of both motors is obtained.

When synchronism in both motors and the disks or adapters of the transmitter and the receiver has been reached, the proper phase relationship is achieved in the receiver in the following manner:

By turning the knob 29, which in turn moves the shell of the motor 24, the speed of the filter disk may be proportionately accelerated or retarded according to rotation, and the shaft 7 is fixed against accidental rotation when the proper phase relationship is found, which will be evidenced by the same fluorescent screen when the colors of the image appear on it distributed.

In connection with the adapter of the transmitter, the knob 29 is moved to make adjustments relative to the position of the disk, and such a manner that the passage of a filter front of the lens is made to coincide perfectly with the scanning of a picture. This is experimentally done through the aid of a receiver employed as a monitor and once this adjustment is obtained, it will remain fixed permanently.

In Figure 5, the circuit wires 44 which connect with the driving motor 23 together with the wires 45 which connect with the power supply of the amplifier 33 are connected with the usual plug 46 to be plugged into an ordinary wall outlet. For convenience, the plug may be dispensed with and the conductors directly connected to the input of the power pack of the receiver or camera, so that the switch of the power pack may be utilized to actuate the adapter. The rheostat 34 is interposed in one of the wires 44. The dissipation of the rheostat watts should be adequate for the motor rating and its total resistance in ohms should be su-

as to reduce the voltage applied to the motor by thirty percent.

Since the shell of the synchronous motor 24 is subjected to movements of the phasing process, the conductors 47 electrically connecting this motor with the amplifier 33 are electrically connected with flexible brushes 48 and 49 pressing against collector rings 50 and 51, respectively, installed one from the other and fixedly connected with the shaft 28 so that current is supplied to the motor 24 through the medium of the collector structure. The terminals 52 of the amplifier 33 may be connected in parallel with two plates of vertical deflection of the cathode ray tube in connection with the television receiver, or to the plates of vertical deflection of an iconoscope in connection with the television camera.

Since the pulsations of the relaxation that are applied to the deflection plates of the cathode ray tubes or iconoscopes are of electrical potentials exclusively (one hundred volts or more) the input circuit of the amplifier 33 presents a high resistance in ohms from binding post to binding post, and thus obtains a minimum in consumption that prevents a fall in the potential applied to the above-mentioned deflecting plates.

The amplifier 33 consists essentially of a stage of low frequency amplification such as that of any audio amplifier and a power pack that supplies it with the necessary voltage for its operation. The circuit of the amplifier is illustrated in Figure 7 by means of symbols such as are employed in the illustration of radio-telephone circuits.

The amplifying tube 53 of this circuit is of type 6L6 and its control grid is conveniently polarized so that its amplifying function will be "class A." Under these conditions the 6L6 tube is capable of rendering a useful power output of 8 watts (maximum). According to the electrical characteristics of a 6L6 tube working "class A," a proper potential has been applied to its screen grid by means of the resistor 54 (10,000 ohms—5 watts). Also the proper polarization of the control grid given by the low resistance 55 connected to the cathode (170 ohms 10 watts). Two condensers 56, 15 mfd., 600 volts breakdown voltage, and 57, 26 mfd., 50 volts breakdown voltage, are connected to the screen grid and cathode, respectively, performing a decoupling function to ground (negative).

The voltage of 400 volts required by the plate of the tube 53 as well as the current for lighting its filament are supplied by the power pack. This power pack consists of a power transformer 58 with four windings: a primary that is connected to the supply line through a switch 59; a secondary of 6.3 volts—3 amperes, for heating the 6L6; another secondary of 5 volts—5 amperes for heating a twin-plate rectifying tube 60; and a high-voltage secondary winding (800 volts—100 ma.) with center tap connection to

ground. The two high-voltage terminals are connected to each plate of the rectifier 60 which is of the 5Z3 type. This tube 60 rectifies a current of 400 volts—100 ma., in the usual manner, which is then "filtered" when passing through a 30 henry choke 61 and two condensers 62 and 64 of 8 mfd., each. The voltage impulses coming from the cathode ray tube or from the iconoscope and which are applied to the input binding posts 52 are capacitively conducted by the bypass condensers 64 and 65 of .1 mfd., each to the 1,000,000 ohms resistance of the potentiometer 66. The movable arm of this potentiometer will be adjusted at the point where it will apply to the grid of the 6L6, to which it is connected, a proper "pulsation-voltage" in order that this tube will work at its maximum undistorted power output.

The proper polarization for the control grid is obtained by means of the resistor 55 connected to the cathode (170 ohms 10 watts).

Finally, in series with the plate circuit of the tube 53 is connected the primary of 5000 ohms impedance of an audio-frequency transformer 67 whose secondary is connected to the output binding posts 68 which in turn are to be connected to the synchronous motor. It is important to note that both the synchronous motor and the secondary of the transformer 67 have similar impedances in order to prevent undue "heatings" and thus obtain the maximum output. All parts of the amplifier are mounted on a small metal chassis so that it can be installed in any place, also for convenience, in any spare space within the same cabinet of the set where the chromoscopic adapter is to be installed. The way of mounting the adapter differs in each case depending upon the apparatus that is being handled.

I claim:

A chromoscopic adapter for television apparatus comprising light filters, a drive shaft, a support for said light filters fixedly connected with said support, said light filters being of different colors and rotating in a common path about the axis of said drive shaft, a relatively fixed base, a driving motor mounted on said base and connected with said drive shaft, a synchronous motor coupled to the armature of said driving motor to control the speed thereof, said synchronous motor comprising a rotor having three equally spaced wings connected as a unit and rotating relatively to two electromagnetic poles fixed to the shell of the synchronous motor, a controlling shaft rotatably mounted on said base and having resilient connections with the shell of the synchronous motor, the shell of the synchronous motor being free floating relatively to said base, and means for yieldingly latching said control shaft against accidental rotation.

GUILLERMO GONZÁLEZ CAMARENA.