

Voltage Feedback Vs Current Feedback Op Amps

Application Report

Voltage Feedback Vs Current Feedback Op Amps Application Report

James Karki

Literature Number: SLVA051
November 1998



Printed on Recycled Paper

Contents

| | | |
|------------|------------------------------------------------|-----|
| 1 | Introduction | 1 |
| 2 | Ideal Models | 2 |
| 3 | Ideal Models with Feedback | 3 |
| 4 | Frequency Dependant Gain Model | 5 |
| 5 | Feedback with Frequency Dependant Models | 7 |
| 6 | Summary | 10 |
| Appendix A | Derivation of Models | A-1 |

List of Figures

| | | |
|---|------------------------------------------------|---|
| 1 | Ideal Op Amp Model | 2 |
| 2 | Noninverting Amplifier | 3 |
| 3 | Frequency Model | 5 |
| 4 | Feedback with Frequency Dependant Models | 7 |
| 5 | Bode Plot | 9 |

Voltage Feedback Vs Current Feedback Op Amps

ABSTRACT

This application report contrasts and compares the characteristics and capabilities of voltage and current feedback operational amplifiers. The report also points out the many similarities between the two versions.

1 Introduction

The voltage feedback (VF) operational amplifier (op amp) is the most common type of op amp. The less well known current feedback (CF) op amp has been commercially available for about 20 years, but many designers are still uncertain about how to use them. Terminology is a confusing factor for many people. The CF op amp is a transimpedance op amp and so has a different vocabulary associated with it. This report attempts to show that there are more similarities than differences between CF and VF op amps when considering basic circuit operation.

2 Ideal Models

The ideal VF op amp model is a powerful tool that aids in understanding basic VF op amp operation. There is also an ideal model for the CF op amp. Figure 1 (a) shows the VF ideal model and Figure 1 (b) shows the CF ideal model.

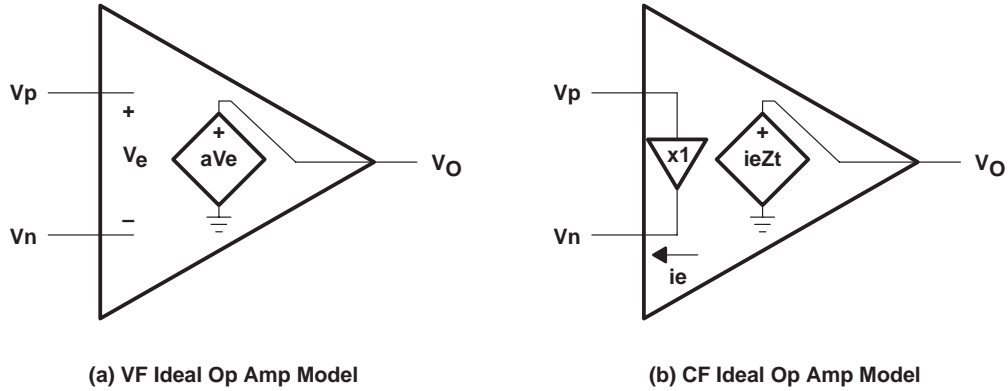

Figure 1. Ideal Op Amp Model

In a VF op amp,

$$V_o = a \times V_e \tag{1}$$

where $V_e = V_p - V_n$ is called the error voltage and a is the open loop voltage gain of the amplifier.

In a CF op amp,

$$V_o = i_e \times Z_t \tag{2}$$

where i_e is called the error current and Z_t is the open loop transimpedance gain of the amplifier. An amplifier where the output is a voltage that depends on the input current is called a transimpedance amplifier because the *transfer* function equates to an *impedance* i.e., $\frac{V_o}{i_e} = Z_t$.

3 Ideal Models with Feedback

Applying negative feedback around the ideal models, as shown in Figure 2 (a) and Figure 2 (b), results in noninverting amplifiers. In a VF op amp, when negative feedback is applied, the action of the op amp is to drive the error voltage to zero; thus the name voltage feedback. In a CF op amp, when negative feedback is applied, the action of the op amp is to drive the error current to zero; thus the name current feedback.

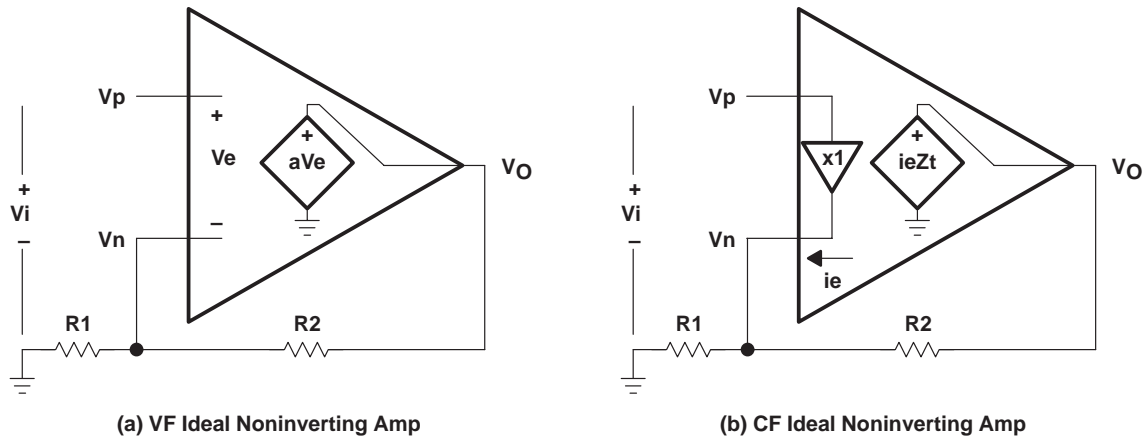

Figure 2. Noninverting Amplifier

For each circuit, solving for V_o in relation to V_i gives the transfer function of the circuit. In the VF circuit, Equation 1 still holds true so that, $V_o = a \times V_e$ where $V_e = V_p - V_n$. Now $V_p = V_i$ and $V_n = V_o \frac{R_1}{R_1 + R_2}$. Substituting and solving for $\frac{V_o}{V_i}$,

$$\frac{V_o}{V_i} = \left[\frac{a}{1 + a \left(\frac{R_1}{R_1 + R_2} \right)} \right] = \left(\frac{R_1 + R_2}{R_1} \right) \left[\frac{1}{1 + \left(\frac{1}{a} \right) \left(\frac{R_1 + R_2}{R_1} \right)} \right] = \left(\frac{1}{b} \right) \left[\frac{1}{1 + \left(\frac{1}{ab} \right)} \right] \quad (3)$$

$$\text{where } b = \left(\frac{R_1}{R_1 + R_2} \right)$$

In the CF circuit, Equation 2 still holds true so that, $V_o = ie \times Z_t \Rightarrow ie = \frac{V_o}{Z_t}$. Also, $V_n = V_p = V_i$. Summing currents at node V_n , $(-ie) + \left(\frac{V_n}{R_1} \right) + \left(\frac{V_n - V_o}{R_2} \right) = 0$. Substituting and solving for $\frac{V_o}{V_i}$;

$$\frac{V_o}{V_i} = \left(\frac{R_1 + R_2}{R_1} \right) \left[\frac{1}{1 + \left(\frac{R_2}{Z_t} \right)} \right] = \left(\frac{1}{b} \right) \left[\frac{1}{1 + \left(\frac{R_2}{Z_t} \right)} \right] \text{ where } b = \left(\frac{R_1}{R_1 + R_2} \right) \quad (4)$$

In either circuit (VF or CF noninverting amplifier), it is desired to set the gain by the ratio of R_1 to R_2 . The second term on the right hand side of Equations 3 and 4 is seen as an error term. In the VF case, if ab is large (ideally equal to infinity), then the error is negligible. In the CF case, if Z_t is large (ideally equal to infinity) in comparison to R_2 , then the error is negligible.

Comparing the ideal behavior of VF and CF amplifiers shows very little difference.

4 Frequency Dependand Gain Model

The open loop gain, a for VF or Z_t for CF, is frequency dependand in real op amps. In Figure 3, components are added to the ideal models (of Figure 1), which model the dominant bandwidth limitations. See Appendix A for the derivation of these models.

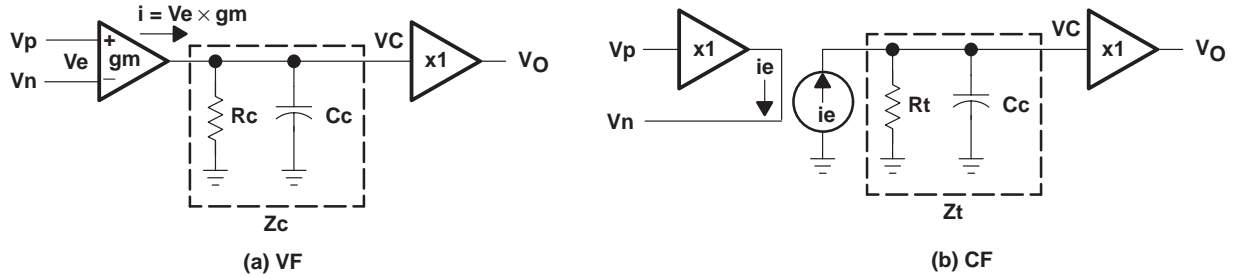

Figure 3. Frequency Model

To solve the input to output transfer function is the same as above.

For the VF op amp:

$$V_o = V_c = i \times Z_c = V_e \times g_m \times (R_c \parallel C_c) . \quad (5)$$

$$\text{Rearranging and substituting } R_c \parallel C_c = \frac{R_c}{1 + j2\pi f R_c C_c}$$

$$\frac{V_o}{V_e} = g_m \left(\frac{R_c}{1 + j2\pi f R_c C_c} \right) . \quad (6)$$

This is the same as Equation 1 with $a = g_m \left(\frac{R_c}{1 + j2\pi f R_c C_c} \right)$.

The term $g_m \left(\frac{R_c}{1 + j2\pi f R_c C_c} \right)$ is the open loop gain of the op amp, usually denoted as $a(f)$ in the literature. The VF op amp's open loop gain has a dc response, a break frequency, and a -20dB/dec roll-off. At low frequencies, $2\pi f R_c C_c \ll 1$, and $\left| \frac{V_o}{V_e} \right| \cong g_m \times R_c$, which is extremely high at dc. As

frequency increases, eventually $2\pi f R_c C_c = 1$, and $\left| \frac{V_o}{V_e} \right| = (g_m \times R_c) \left(\frac{1}{\sqrt{2}} \right)$.

This is the dominant pole frequency, f_D . At frequencies above f_D , C_c begins to dominate the response so that $\left| \frac{V_o}{V_e} \right| \cong \frac{g_m}{2\pi f C_c}$, and the gain rolls off at -20dB/dec . C_c is usually chosen so that the amplification falls to unity [noted as F_u in Figure 5(a)] before upper frequency poles cause excessive phase shift.

For the CF op amp:

$$V_o = V_c = i_e \times Z_t = i_e \times (R_c \parallel C_c) . \quad (7)$$

Rearranging and substituting $R_c \parallel C_c = \frac{R_c}{1 + j2\pi f R_t C_c}$

$$\frac{V_o}{i_e} = \left(\frac{R_t}{1 + j2\pi f R_t C_c} \right) .$$

This is the same as Equation 2 with $Z_t = \left(\frac{R_t}{1 + j2\pi f R_t C_c} \right)$

The term $Z_t = \frac{R_t}{1 + j2\pi f R_t C_c}$ is the open loop gain of the op amp, which is frequency dependent, and is more properly denoted $Z_t(f)$. The CF op amp's open loop gain has a dc response, a break frequency, and a -20dB/dec roll off. At low frequencies, $2\pi f R_t C_c \ll 1$, and $\left| \frac{V_o}{i_e} \right| \cong R_t$, which is extremely high at dc. As frequency increases, eventually $2\pi f R_t C_c = 1$, and $\left| \frac{V_o}{i_e} \right| = \frac{R_t}{\sqrt{2}}$. This is the dominant pole frequency, f_D . At frequencies above f_D , C_c begins to dominate the response so that $\left| \frac{V_o}{i_e} \right| \cong \frac{1}{2\pi f C_c}$, and the gain rolls off at -20dB/dec . C_c is usually chosen so that Z_t will roll off to the desired feedback resistor value before upper frequency poles cause excessive phase shift.

5 Feedback with Frequency Dependant Models

Applying a negative feedback network (as in Figure 2) to the op amp frequency models as shown in Figure 4 results in noninverting amplifiers.

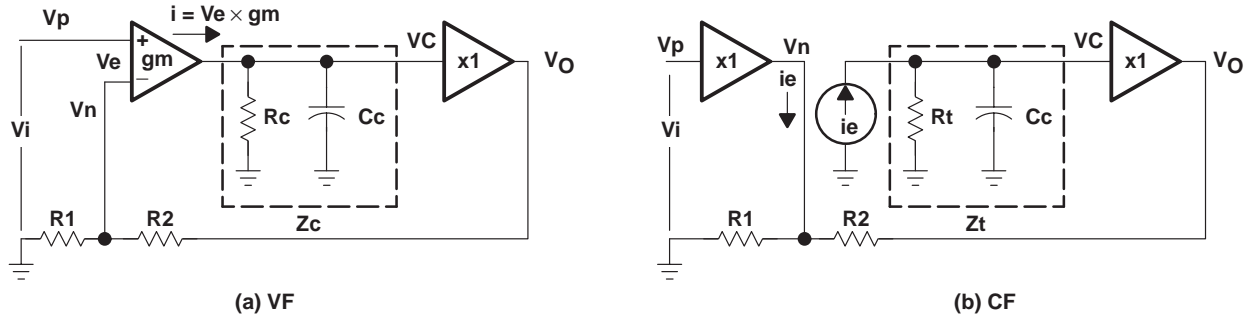

Figure 4. Feedback with Frequency Dependant Models

Solve the transfer function for the VF noninverting amplifier by substituting

$$a = gm \left(\frac{Rc}{1 + j2\pi f Rc Cc} \right) \text{ in Equation 3. Therefore :} \quad (8)$$

$$\frac{Vo}{Vi} = \left(\frac{R1 + R2}{R1} \right) \left[\frac{1}{1 + \frac{1}{gm \left(\frac{Rc}{1 + j2\pi f Rc Cc} \right) \left(\frac{R1}{R1 + R2} \right)}} \right]$$

The gain-bandwidth relationship of the VF noninverting amplifier can be seen clearly by expanding and collecting terms in the second term on the right hand side of Equation 8.

$$\begin{aligned} \left[\frac{1}{1 + \frac{1}{gm \left(\frac{Rc}{1 + j2\pi f Rc Cc} \right) \left(\frac{R1}{R1 + R2} \right)}} \right] &= \left[\frac{1}{1 + \frac{(R1 + R2)(1 + j2\pi f Rc Cc)}{gm \times Rc \times R1}} \right] \quad (9) \\ &= \left[\frac{1}{1 + \left(\frac{1}{gm \times Rc} \right) \left(\frac{R1 + R2}{R1} \right) + \left(\frac{R1 + R2}{R1} \right) \left(\frac{j2\pi f Cc}{gm} \right)} \right] \end{aligned}$$

Usually $gm \times Rc$ is very large so that $\left(\frac{1}{gm \times Rc} \right) \left(\frac{R1 + R2}{R1} \right) \ll 1$. Disregarding this term and substituting Equation 9 into Equation 8 results in

$$\frac{V_o}{V_i} \cong \left(\frac{R1 + R2}{R1} \right) \left[\frac{1}{1 + \left(\frac{R1}{R1 + R2} \right) \left(\frac{j2\pi f Cc}{gm} \right)} \right] \quad (10)$$

The term $\left(\frac{R1 + R2}{R1} \right)$ is the desired closed loop gain of the amplifier. (11)

At low frequency where $\left(\frac{R1 + R2}{R1} \right) \left(\frac{j2\pi f Cc}{gm} \right) \ll 1j$, $\left| \frac{V_o}{V_i} \right| \cong \left(\frac{R1 + R2}{R1} \right)$.

As frequency increases, eventually $\left(\frac{R1}{R1 + R2} \right) \left(\frac{j2\pi f_c Cc}{gm} \right) = 1j$

and the gain of the circuit is reduced by 3 dB: $\left| \frac{V_o}{V_i} \right| \cong \left(\frac{R1 + R2}{R1} \right) \left(\frac{1}{\sqrt{2}} \right)$. The

frequency $f_c = \left(\frac{gm}{2\pi Cc} \right) \left(\frac{R1}{R1 + R2} \right)$ is the -3 dB bandwidth, or cutoff frequency

of the circuit. Rearranging, $(f_c) \left(\frac{R1 + R2}{R1} \right) = \left(\frac{gm}{2\pi Cc} \right) = \text{constant}$. Therefore, in

a voltage feedback op amp, the product of the closed loop gain and the closed loop bandwidth is constant over most of the frequencies of operation. This is the gain bandwidth product, (GBP). The result is that if gain is multiplied by 10, bandwidth is divided by 10.

Solve the transfer function for the CF noninverting amplifier by substituting

$Z_t = \frac{R_t}{1 + j2\pi f R_t C_c}$ in Equation 4. Therefore:

$$\begin{aligned} \frac{V_o}{V_i} &= \left(\frac{R1 + R2}{R1} \right) \left[\frac{1}{1 + (R2) \left(\frac{1 + j2\pi f R_t C_c}{R_t} \right)} \right] \\ &= \left(\frac{R1 + R2}{R1} \right) \left[\frac{1}{1 + \left(\frac{R2}{R_t} \right) + (j2\pi f R2 C_c)} \right] \end{aligned} \quad (12)$$

Normally $\frac{R2}{R_t} \ll 1$ and is disregarded resulting in:

$$\frac{V_o}{V_i} \cong \left(\frac{R1 + R2}{R1} \right) \left[\frac{1}{1 + (j2\pi f R2 C_c)} \right] \quad (13)$$

Equation 13 shows that the -3dB bandwidth or cutoff frequency, f_c , can be set by selection of $R2$ so that $f_c = \frac{1}{2\pi R2 C_c}$, and gain can be set by selection of $R1$.

Thus in a CF op amp gain and bandwidth are independent of each other.

Figure 5 shows Bode plots of the gain vs. frequency characteristics of the VF and CF op amp models.

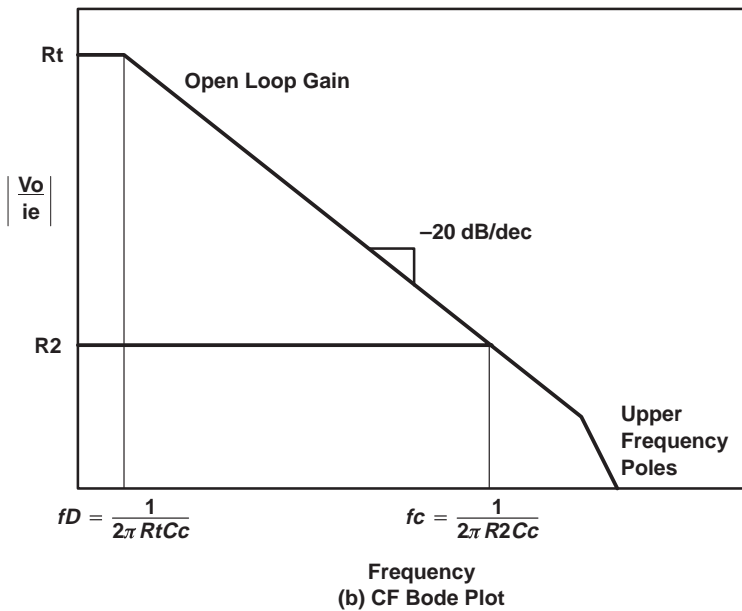
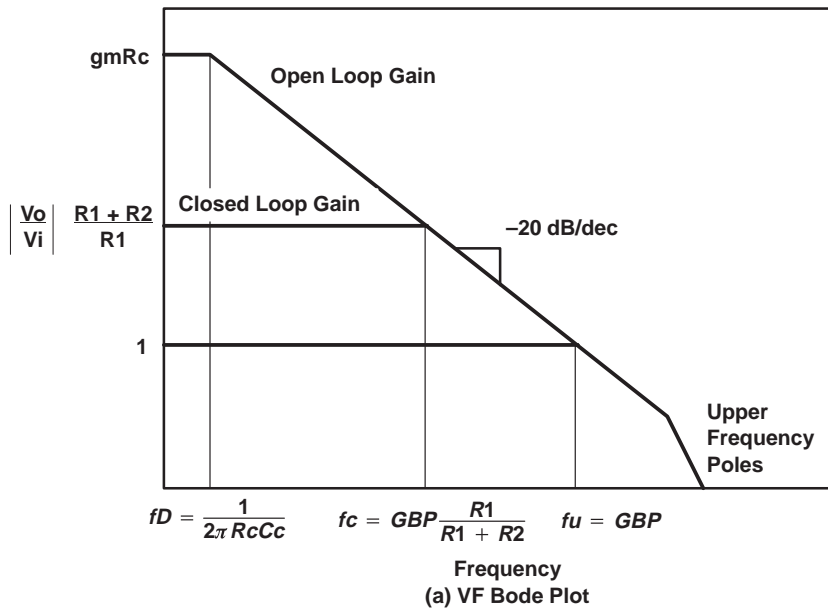

Figure 5. Bode Plot

6 Summary

A VF op amp is a voltage amplifier $\frac{V_o}{V_e} = a(f)$ and a CF op amp is a transimpedance amplifier $\frac{V_o}{i_e} = Z_t(f)$. In each the effect of negative feedback is to drive the input to zero: $V_e \rightarrow 0$ and $i_e \rightarrow 0$; thus the names VF and CF. When configured as noninverting amplifiers with negative feedback, both op amps provide a voltage gain that is determined by the feedback network. In each the open loop gains, $a(f)$ and $Z_t(f)$, are frequency-dependent and limit the bandwidth of operation. In VF op amp circuits the gain bandwidth product is constant over the normal frequencies of operation. In CF op amp circuits the gain and bandwidth can be set independently of one another.

The majority of VF op amps are unity-gain stable, so the designer is relieved of the burden of compensating circuits for stable operation. This also limits bandwidth to the minimum capability of the op amp design.

The impedance of the negative feedback component determines stability in a CF op amp circuit. There is a minimum value of R_2 to maintain stability (conversely there is a maximum bandwidth for a given phase margin). For this reason, if a buffer amplifier is configured by shorting the output to the negative input, the circuit will oscillate. Also, care must be taken when using capacitance in the feedback loop as in the case of an integrator or low pass filter.

Table 1. VF vs CF: Comparison of Major Parameters

| PARAMETER | VF | CF |
|------------------------|-----------------------------------------------------------------------------------------------------|--------------------------------------------------------------------------------------------------------|
| Open loop gain | Voltage $\frac{V_o}{V_e} = a(f)$. Frequency dependant, limits bandwidth. | Transimpedance $\frac{V_o}{i_e} = Z_t(f)$. Frequency dependant, limits bandwidth. |
| Closed loop gain | $\frac{V_o}{V_i} = \left(\frac{1}{b}\right) \left[\frac{1}{1 + \left(\frac{1}{ab}\right)} \right]$ | $\frac{V_o}{V_i} = \left(\frac{1}{b}\right) \left[\frac{1}{1 + \left(\frac{R_2}{Z_t}\right)} \right]$ |
| Ideal closed loop gain | Set by feedback factor $\left(\frac{1}{b}\right)$ | Set by feedback factor $\left(\frac{1}{b}\right)$ |
| Gain bandwidth product | Gain and bandwidth interdependent. Constant over most frequencies of operation. | Gain and bandwidth independent of each other. |
| Stability | Normally unity gain stable. | Minimum impedance in feedback component required for stability |
| Bandwidth | Set by closed loop gain | Set by impedance of feedback component |

Appendix A Derivation of Models

Figure A1 and Figure A2 show simplified schematic diagrams of the THS4001 and THS3001, and their models. The following discussion provides an overview of how the frequency dependent models are derived.

A.1 THS4001 – VF Frequency Dependent Model (see Figure A–1)

A.1.1 Differential Pair

Q1 and Q2 comprise the input differential pair. Three current sources, i , are used to bias the circuit for normal operation; $i=i_1+i_2$.

- When $V_p=V_n$, $i_1=i_2$, and the collector currents of Q1, Q2, Q3, and Q4 are equal.
- When $V_p>V_n$, Q2 turns on harder and i_2 increases. The bottom current source insures that $i=i_1+i_2$. Therefore i_1 decreases..
- When $V_p<V_n$, Q1 turns on harder and i_1 increases. The bottom current source insures that $i=i_1+i_2$. Therefore i_2 decreases.

Thus the differential voltage at the input V_n and V_p causes differential currents to be generated in Q3 and Q4. The differential input stage is modeled by the transconductance amplifier, gm .

A.1.2 High Impedance

The current, i_2 , develops voltage, V_c , at the high impedance node formed by the current mirror structure, D5–Q5 and D6–Q6, and capacitor C_c . The high impedance stage is modeled by the parallel impedance, $Z_c = R_c \parallel C_c$. R_c models the equivalent dc resistance to ground. C_c is actually two capacitors; one to the positive supply and one to the negative supply. C_c is the parallel combination and the supply pins are assumed to be ac grounds.

A.1.3 Double Output Buffer

Q7 through Q10 form a double buffer that is a class AB amplifier. The voltage V_c is buffered to the output so that $V_o=V_c$. The double output buffer is modeled by the X1 buffer amplifier.

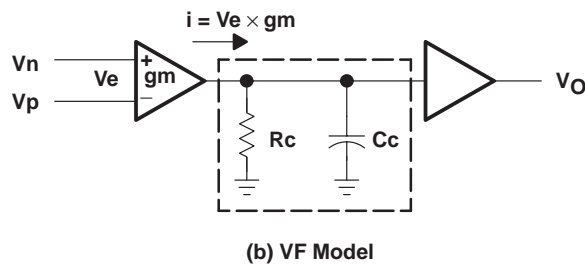
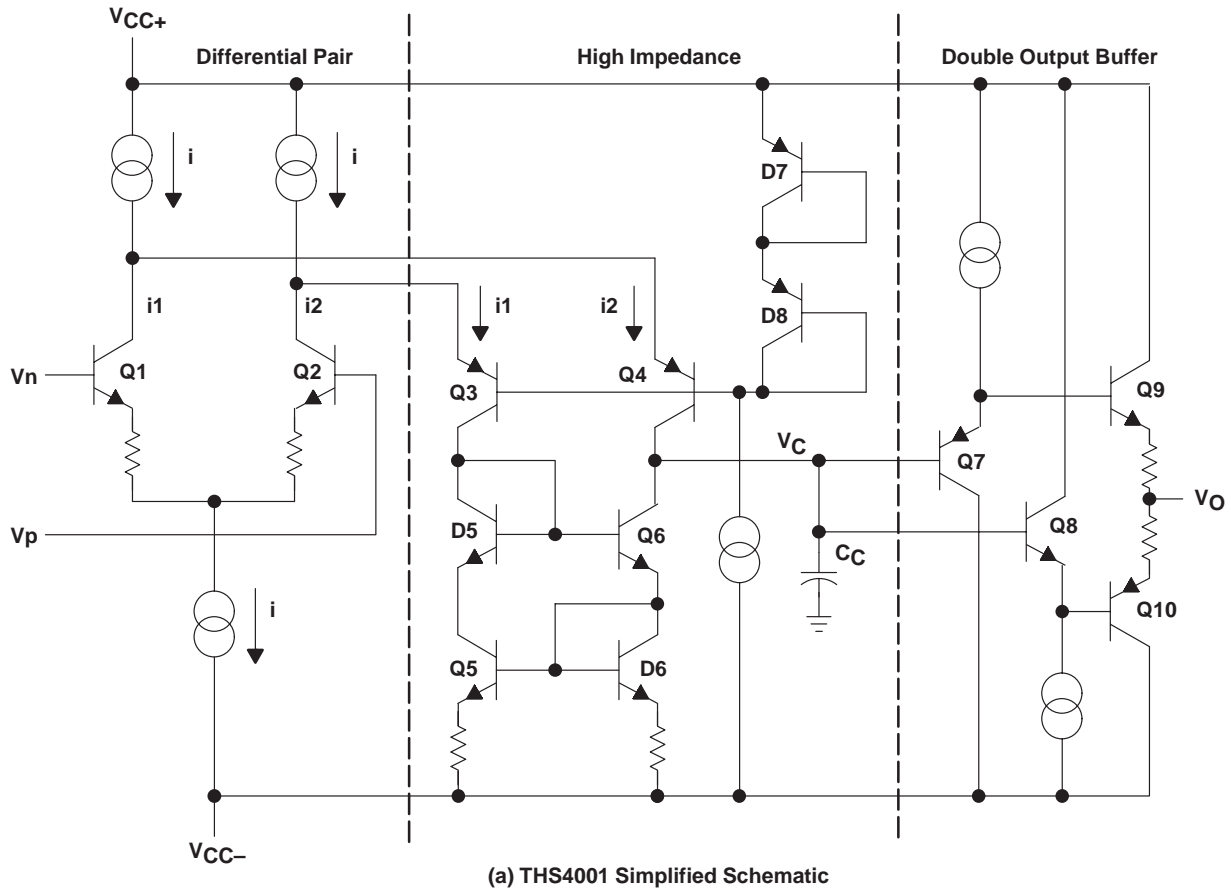

Figure A-1. VF Model Derivation

A.2 THS3001 – CF Frequency Dependent Model (see Figure A-2)

A.2.1 Class AB Amplifier

D1–Q1 and D2–Q2 comprise a class AB amplifier where the signal at V_p is buffered with a gain of 1 to V_n . The input stage is modeled by the X1 buffer amplifier between V_p and V_n .

A.2.2 Current Mirror

The collector current of Q1 is drawn through D3. D3–Q3 form a current mirror so that the collector current of Q3 equals the collector current of Q1. The same is true for the bottom side so that Q2’s current is mirrored by Q4. This is modeled as a current source equal to the input error current driving the high impedance.

A.2.3 High Impedance

The current, $i1$ or $i2$, develops voltage, Vc , at the high impedance node, D5–D6, and Cc . The high impedance is modeled by parallel impedance, $Zt = Rt \parallel Cc$. Rt models the equivalent dc resistance to ground. Cc is actually two capacitors; one to the positive supply and one to the negative supply. Cc is the parallel combination and the supply pins are assumed to be ac grounds.

A.2.4 Triple Output Buffer

Q5 through Q10 form a triple buffer that is a class AB amplifier. The voltage Vc is buffered to the output so that $Vo = Vc$. The triple output buffer is modeled by the X1 buffer amplifier.

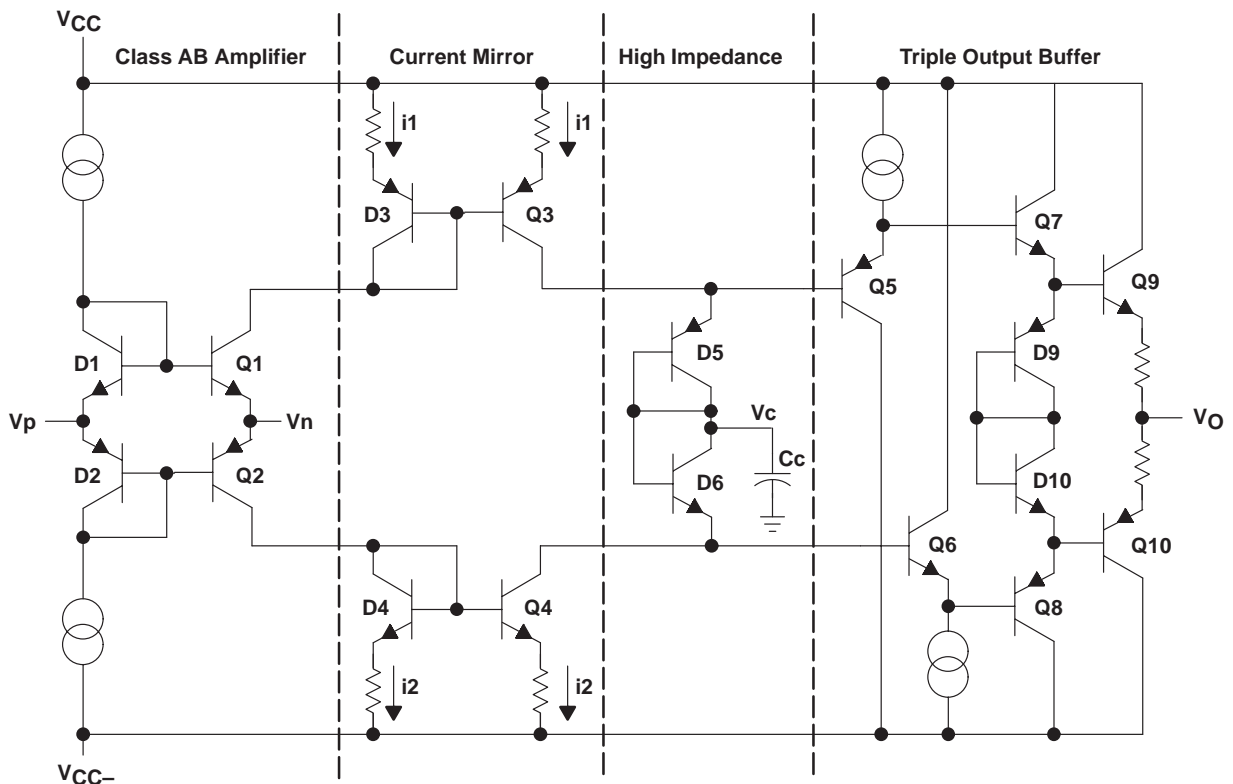

(a) THS3001 Simplified Schematic

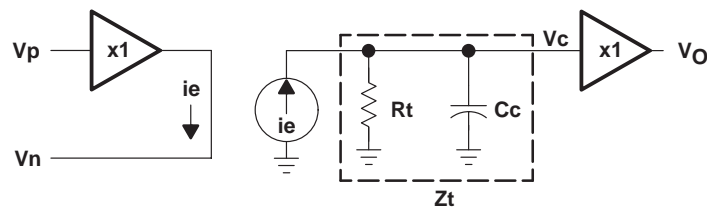

(b) CF Model

Figure A–2. CF Model Derivation

IMPORTANT NOTICE

Texas Instruments and its subsidiaries (TI) reserve the right to make changes to their products or to discontinue any product or service without notice, and advise customers to obtain the latest version of relevant information to verify, before placing orders, that information being relied on is current and complete. All products are sold subject to the terms and conditions of sale supplied at the time of order acknowledgment, including those pertaining to warranty, patent infringement, and limitation of liability.

TI warrants performance of its products to the specifications applicable at the time of sale in accordance with TI's standard warranty. Testing and other quality control techniques are utilized to the extent TI deems necessary to support this warranty. Specific testing of all parameters of each device is not necessarily performed, except those mandated by government requirements.

Customers are responsible for their applications using TI components.

In order to minimize risks associated with the customer's applications, adequate design and operating safeguards must be provided by the customer to minimize inherent or procedural hazards.

TI assumes no liability for applications assistance or customer product design. TI does not warrant or represent that any license, either express or implied, is granted under any patent right, copyright, mask work right, or other intellectual property right of TI covering or relating to any combination, machine, or process in which such products or services might be or are used. TI's publication of information regarding any third party's products or services does not constitute TI's approval, license, warranty or endorsement thereof.

Reproduction of information in TI data books or data sheets is permissible only if reproduction is without alteration and is accompanied by all associated warranties, conditions, limitations and notices. Representation or reproduction of this information with alteration voids all warranties provided for an associated TI product or service, is an unfair and deceptive business practice, and TI is not responsible nor liable for any such use.

Resale of TI's products or services with statements different from or beyond the parameters stated by TI for that product or service voids all express and any implied warranties for the associated TI product or service, is an unfair and deceptive business practice, and TI is not responsible nor liable for any such use.

Also see: [Standard Terms and Conditions of Sale for Semiconductor Products](http://www.ti.com/sc/docs/stdterms.htm), www.ti.com/sc/docs/stdterms.htm

Mailing Address:

Texas Instruments
Post Office Box 655303
Dallas, Texas 75265

Copyright © 2001, Texas Instruments Incorporated

IMPORTANT NOTICE

Texas Instruments and its subsidiaries (TI) reserve the right to make changes to their products or to discontinue any product or service without notice, and advise customers to obtain the latest version of relevant information to verify, before placing orders, that information being relied on is current and complete. All products are sold subject to the terms and conditions of sale supplied at the time of order acknowledgment, including those pertaining to warranty, patent infringement, and limitation of liability.

TI warrants performance of its products to the specifications applicable at the time of sale in accordance with TI's standard warranty. Testing and other quality control techniques are utilized to the extent TI deems necessary to support this warranty. Specific testing of all parameters of each device is not necessarily performed, except those mandated by government requirements.

Customers are responsible for their applications using TI components.

In order to minimize risks associated with the customer's applications, adequate design and operating safeguards must be provided by the customer to minimize inherent or procedural hazards.

TI assumes no liability for applications assistance or customer product design. TI does not warrant or represent that any license, either express or implied, is granted under any patent right, copyright, mask work right, or other intellectual property right of TI covering or relating to any combination, machine, or process in which such products or services might be or are used. TI's publication of information regarding any third party's products or services does not constitute TI's approval, license, warranty or endorsement thereof.

Reproduction of information in TI data books or data sheets is permissible only if reproduction is without alteration and is accompanied by all associated warranties, conditions, limitations and notices. Representation or reproduction of this information with alteration voids all warranties provided for an associated TI product or service, is an unfair and deceptive business practice, and TI is not responsible nor liable for any such use.

Resale of TI's products or services with statements different from or beyond the parameters stated by TI for that product or service voids all express and any implied warranties for the associated TI product or service, is an unfair and deceptive business practice, and TI is not responsible nor liable for any such use.

Also see: [Standard Terms and Conditions of Sale for Semiconductor Products](http://www.ti.com/sc/docs/stdterms.htm). www.ti.com/sc/docs/stdterms.htm

Mailing Address:

Texas Instruments
Post Office Box 655303
Dallas, Texas 75265